

Steel Handles:
8 Places

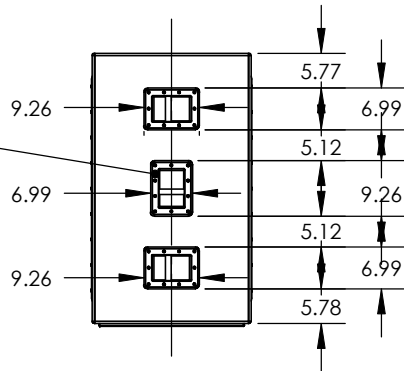

Caster Board
4 Casters
Two Handles
Two Twist Locks
Skid Recesses

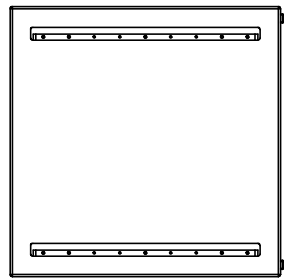
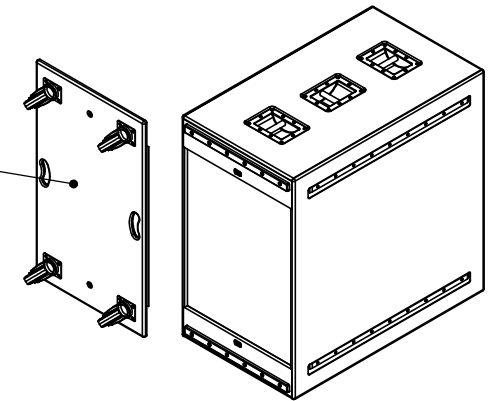

Skids For
Caster Board
2 Places

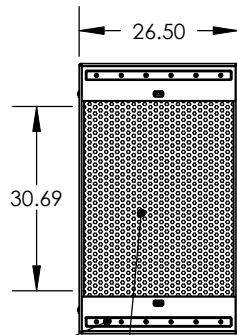

Grill

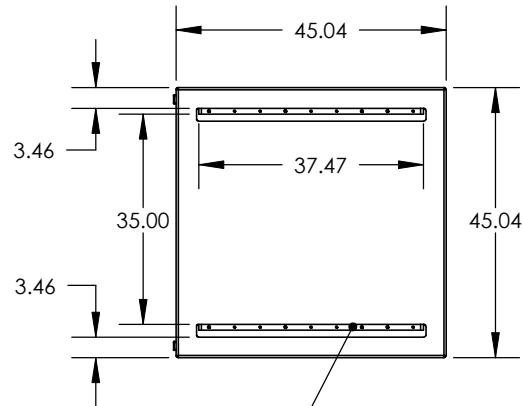
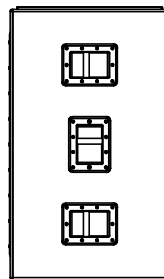

Locking Skids
Top & Bottom

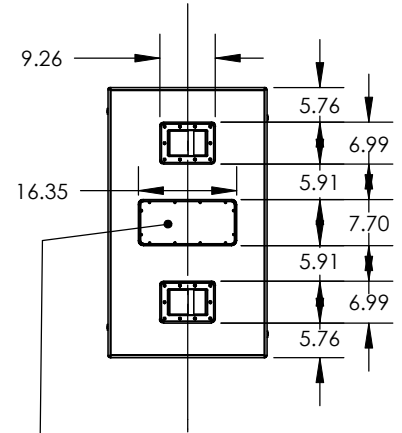

SP1/SP2 Amp Chassis

PROPRIETARY AND CONFIDENTIAL
THE INFORMATION CONTAINED IN THIS DRAWING IS THE SOLE PROPERTY OF QUALITY MUSICAL SYSTEMS, INC. ANY REPRODUCTION IN PART OR AS A WHOLE WITHOUT THE WRITTEN PERMISSION OF QUALITY MUSICAL SYSTEMS, INC. IS PROHIBITED.

MATERIAL	UNLESS OTHERWISE SPECIFIED: DIMENSIONS ARE IN INCHES TOLERANCES: FRACTIONAL ± ANGULAR: MACH ± BEND ± TWO PLACE DECIMAL ± THREE PLACE DECIMAL ±
FINISH	
DO NOT SCALE DRAWING	

DRAWN	TBW	6/2/2009
ENG APPR.		
MFG APPR.		
Q.A.		

Danley Sound Labs		
TITLE: TH412 (Halfammonster)		
SIZE A	Plan View Drawing	REV 1
SCALE: 1:32	Last Save Date: Tuesday, June 02, 2009 11:18:27 AM	