

• = Suspension Point Symbol
 ⊙ = Center of Gravity Symbol

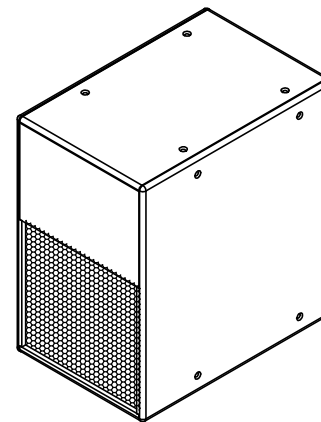

Isometric View

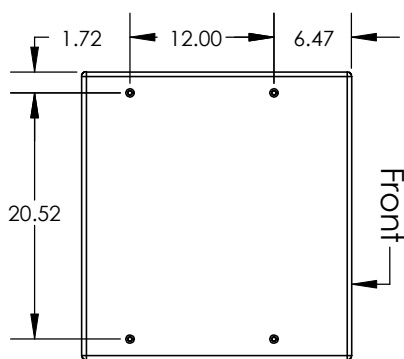

Lt Side

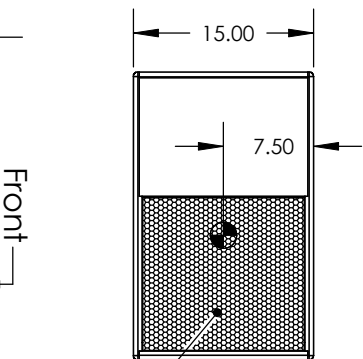

Front Grill

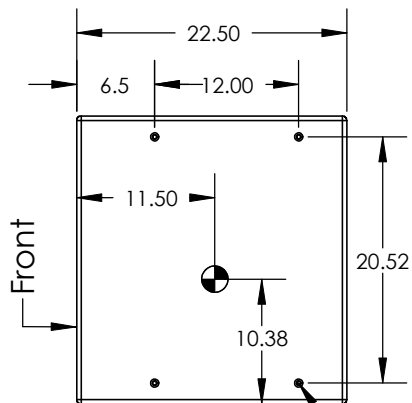

Rt Side

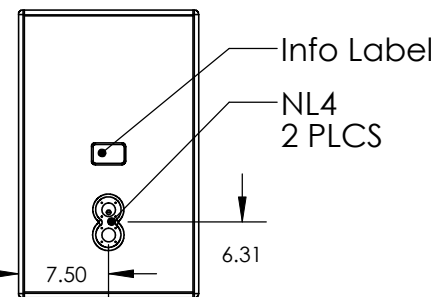

Back

Suspension Points
 3/8"X16 Thread:
 (4) on Top
 (4) on Rt Side
 (4) on Lt Side
 (4) on Bottom

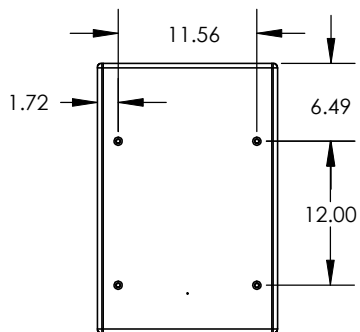

Bottom

PROPRIETARY AND CONFIDENTIAL
 THE INFORMATION CONTAINED IN THIS DRAWING IS THE SOLE PROPERTY OF QUALITY MUSICAL SYSTEMS, INC. ANY REPRODUCTION IN PART OR AS A WHOLE WITHOUT THE WRITTEN PERMISSION OF QUALITY MUSICAL SYSTEMS, INC. IS PROHIBITED.

MATERIAL
FINISH
DO NOT SCALE DRAWING

UNLESS OTHERWISE SPECIFIED:
 DIMENSIONS ARE IN INCHES
 TOLERANCES:
 FRACTIONAL ±
 ANGULAR: MACH ± BEND ±
 TWO PLACE DECIMAL ±
 THREE PLACE DECIMAL ±

DRAWN	TBW	11/12/2008
ENG APPR.		
MFG APPR.		
Q.A.		

Danley Sound Labs		
TITLE: THmini-IN		
SIZE A	Plan View Drawing	REV A
Last Save Date: Wednesday, November 12, 2008 8:02:57 AM		