

Pole Cup on Top When Flown

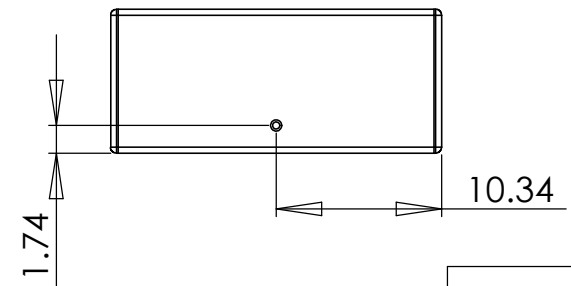
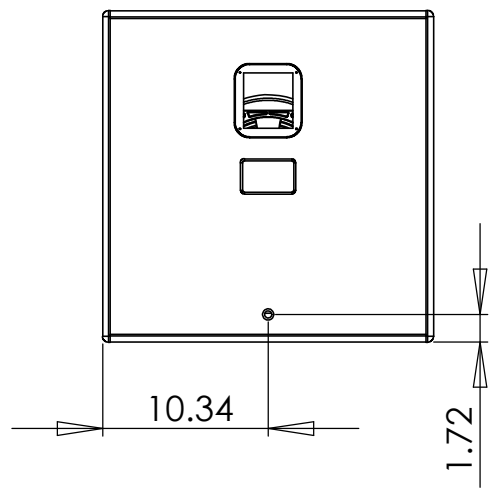
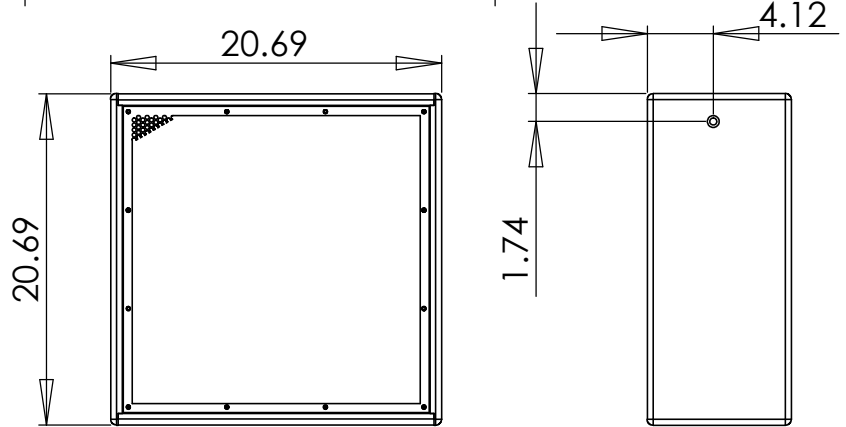
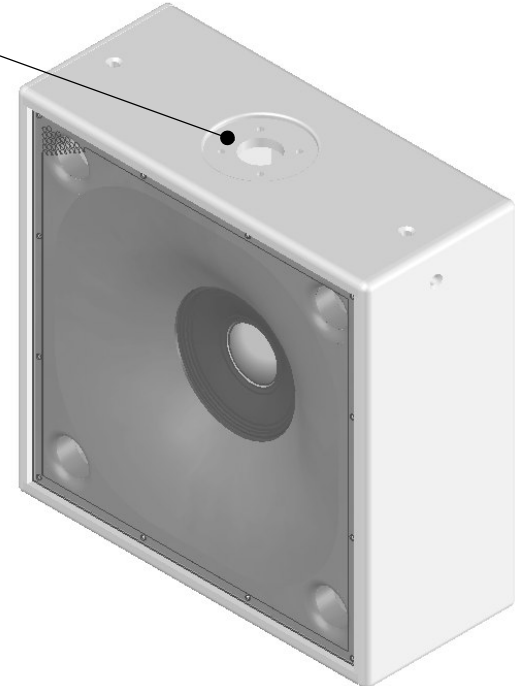

PROPRIETARY AND CONFIDENTIAL
 THE INFORMATION CONTAINED IN THIS DRAWING IS THE SOLE PROPERTY OF QUALITY MUSICAL SYSTEMS, INC. ANY REPRODUCTION IN PART OR AS A WHOLE WITHOUT THE WRITTEN PERMISSION OF QUALITY MUSICAL SYSTEMS, INC. IS PROHIBITED.

		UNLESS OTHERWISE SPECIFIED:		NAME	DATE
		DIMENSIONS ARE IN INCHES	DRAWN	TBW	08/08/06
		TOLERANCES:	CHECKED		
		FRACTIONAL ±0.03	ENG APPR.		
		ANGULAR: MACH ±0.25	MFG APPR.		
		TWO PLACE DECIMAL ±0.30	Q.A.		
		THREE PLACE DECIMAL ±0.15	COMMENTS:		
		INTERPRET GEOMETRIC TOLERANCING PER:			
		MATERIAL			
		Material			
		FINISH			
NEXT ASSY	USED ON				
APPLICATION		DO NOT SCALE DRAWING			

TITLE:
Danley Sound Labs

SIZE	DWG. NO.	REV
A	SH 100	A

SCALE: 1:1	WEIGHT:	SHEET 1 OF 1
------------	---------	--------------